

# Inca Pro Plus

All new versatile pro liner / hood

- professional-style liner / insert hood
- fits custom hoods 36" - 48" wide
- 19" or 22" depth available
- 300, 600 or 1200 internal PRO motor
- 900 or 1200 cfm remote blower
- stainless steel finish
- removable grease rail
- angled baffle filters
- 2 level halogen lights
- variable speed control dial
- restaurant style baffle filters
- convertible to recirculating\*
- sloped front and sides
- 6" or 10" round duct

\* it is highly recommended that professional style cooking always be vented to the outside.



Size	Model #
36" Wide X 19" Depth	INPL3619SS
42" Wide X 19" Depth	INPL4219SS
48" Wide X 19" Depth	INPL4819SS
36" Wide X 22" Depth	INPL3622SS
48" Wide X 22" Depth	INPL4822SS

## Choose A Blower From Below

Internal 300 cfm blower kit	IB300
Internal 600 cfm blower kit	IB600
Internal 1200 cfm blower kit	IB1200
Remote Blower 900 cfm kit	RB900
Remote Blower 1200 cfm kit	RB1200

# Built - In Collection Pro Series



# FABER

ON AIR. SINCE 1955

New All in one Professional Liner from Faber. For custom wood cabinet applications, available in three widths and two depths depending on your needs. With the flexibility of four blower options, the Inca Pro Plus offers the power, style and functionality you need for today's custom pro hood applications.



## ACCESSORIES

### Charcoal Filters FILTER1

For recirculating installations, high quality, heavy duty filters ensure the removal of smoke and odors from the kitchen. Some ductwork is required to exhaust the unit out of the cabinet.



### In-line blower Kit INLBKIT

Use to connect an in-line blower to the range hood

## Dimensional Diagrams

### OVERALL

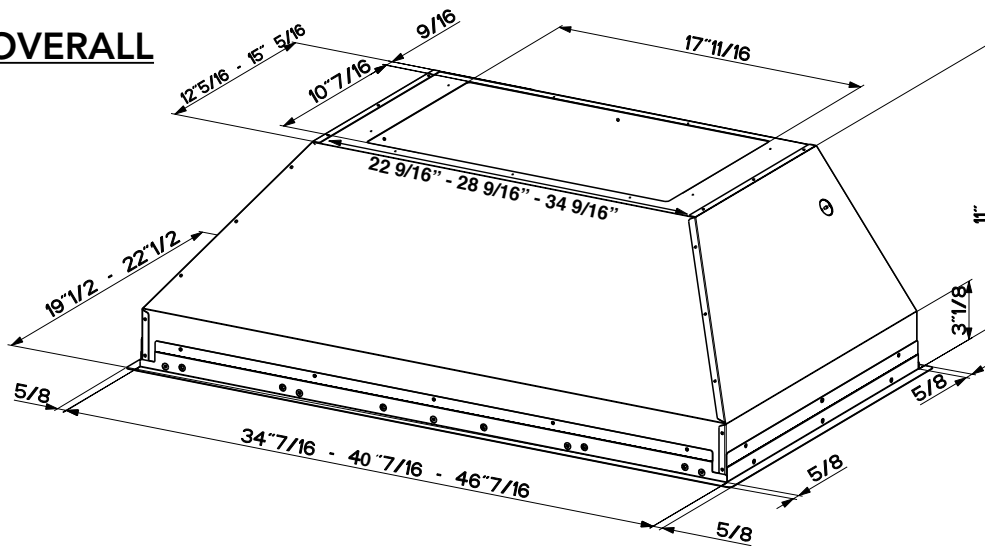

### SIDE

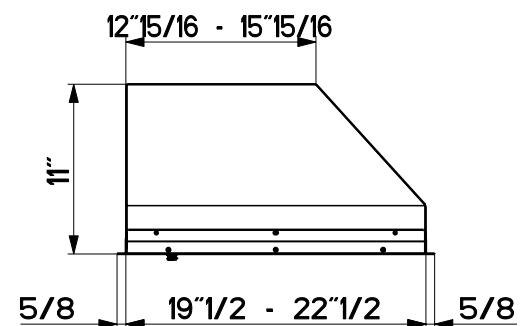

**Pre-Planning Your Installation** - Important: Consult the installation instructions before you begin installing this rangehood. The recommended height to install this hood off the cooktop is a minimum of 30" for maximum effectiveness. Also consult the cooktop manufacturer's recommendation.

**Pre-Planning Your Ductwork** - Important: Consult the installation instructions before you begin installing this rangehood.

Make your ductrun as straight and short as possible. The ductrun should not exceed 35 equivalent feet if ducted with the required minimum of 6" round duct. Count 45° angles as 3 feet, 90° elbows as 5 feet, and 90° flat elbows as 12 feet.

For best results, use no more than three 90° elbows. Make sure that there is a minimum of 24" of straight duct between elbows if more than one is used. Do not install two elbows together. If you must elbow right away, do it as far away from the hood's exhaust opening as possible.

### Recirculating Installations

IT IS HIGHLY RECOMMENDED THAT PROFESSIONAL STYLE COOKING ALWAYS BE VENTED TO THE OUTSIDE. For installations where ductwork to the outside of your home is impossible or highly impractical Charcoal Filters, which attach to the blower assembly, absorb smoke and odors.

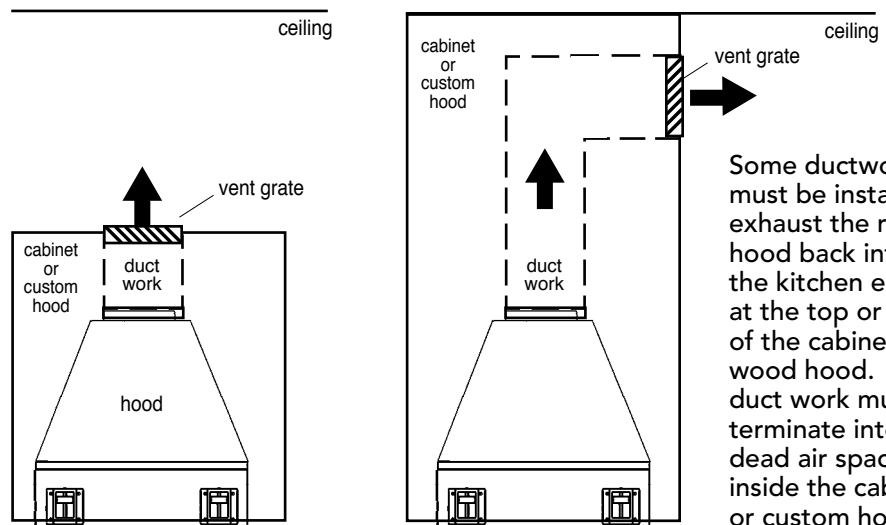

Some ductwork must be installed to exhaust the rangehood back into the kitchen either at the top or face of the cabinet or wood hood. This duct work must not terminate into a dead air space or inside the cabinet or custom hood.

**WARNING!** Product specifications are subject to change without notification. Consult the installation instructions before you begin installing this rangehood.